

Gehäuse und Innenteile:  
 Handrad:  
 Dichtungsmaterial:  
 Betriebsdruck:  
 Medium- und Umgebungstemperatur:  
 Betriebstemperatur:

Edelstahl 1.4401 / 1.4408  
 Aluminium  
 PTFE  
 max. 14,0 bar  
 max. 160 °C  
 -10 °C bis 180 °C

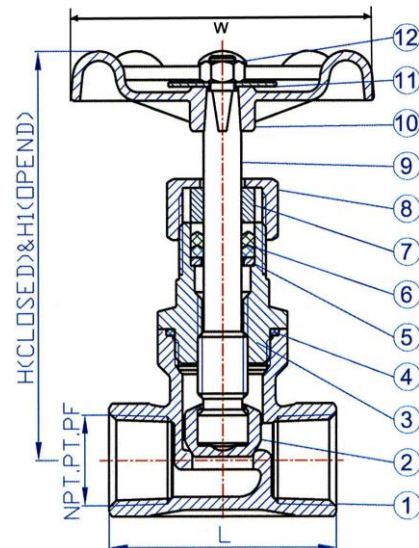

250.52 ES



## Muffen-Absperrventile, Edelstahl

Artikel Nr.	Ident Nr.	Gewinde	DN	L mm	H mm	H1 mm	W mm	Gewicht kg
250.50 ES	103795	G 3/8	10	52,0	89,0	99,0	70,0	0,3
250.51 ES	103796	G 1/2	15	52,0	89,0	99,0	70,0	0,3
250.52 ES	103797	G 3/4	20	66,0	95,0	107,0	80,0	0,5
250.53 ES	103798	G 1	25	76,0	102,0	118,0	80,0	0,7
250.54 ES	103799	G 1 1/4	32	86,0	130,0	150,0	90,0	1,0
250.55 ES	103800	G 1 1/2	40	94,0	132,0	142,0	90,0	1,3
250.56 ES	103801	g 2	50	118,0	154,0	167,0	100,0	2,0

## Ersatzteile

Artikel-Nr.	Handrad ET-Nr.
250.50 ES	250.3.11-ES
250.51 ES	250.3.11-ES
250.52 ES	250.3.11-ES
250.53 ES	250.3.13-ES
250.54 ES	250.3.13-ES
250.55 ES	250.3.15-ES
250.56 ES	250.3.16-ES

**Materialliste**

NO.	PART NAME	MATERIAL
1	BODY	CF8M
2	DISC	CF8M
3	BONNET	CF8M
4	GASKET	PTFE
5	WHORL GASKET	SUS304
6	PACKING	PTFE
7	GLAND	SUS304
8	CAP NUT	CF8M
9	STEM	SUS316
10	HANDLE	ALUMINUM
11	NAMEPLATE	ALUMINUM
12	NUT	SUS304