

Betriebstemperatur:  
Betriebsdruck:

max. 120 °C  
max. 16 bar

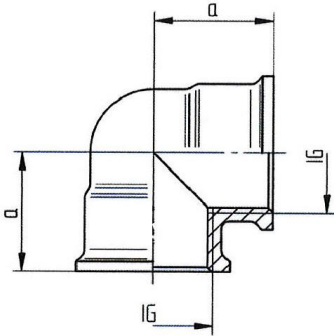

WST34MS90II

### Winkelstück, 90°, innen/innen

Artikel Nr.	Typen Nr.	Gewinde	a mm
194100	WST14MS90II	G 1/4	19,0
194101	WST38MS90II	G 3/8	24,0
194102	WST12MS90II	G 1/2	25,0
194103	WST34MS90II	G 3/4	29,0
194104	WST10MS90II	G 1	34,5
194105	WST114MS90II	G 1 1/4	47,0
194106	WST112MS90II	G 1 1/2	50,0
194107	WST20MS90II	G 2	58,5

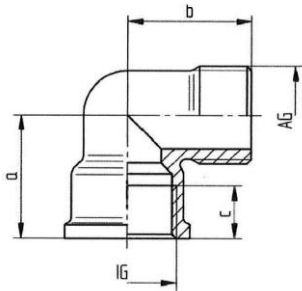

WST34MS90IA

**Winkelstück, 90°, innen/außen**

Artikel Nr.	Typen Nr.	Gewinde	a mm	b mm	c mm
194108	WST14MS90IA	G 1/4	24,5	27,5	10,5
194109	WST38MS90IA	G 3/8	22,0	35,5	11,0
194110	WST12MS90IA	G 1/2	23,0	32,0	13,0
194111	WST34MS90IA	G 3/4	26,0	41,0	12,0
194112	WST10MS90IA	G 1	30,0	49,5	15,0
194113	WST114MS90IA	G 1 1/4	38,0	53,5	17,0
194114	WST112MS90IA	G 1 1/2	41,0	57,0	18,0
194115	WST20MS90IA	G 2	54,0	65,0	24,0

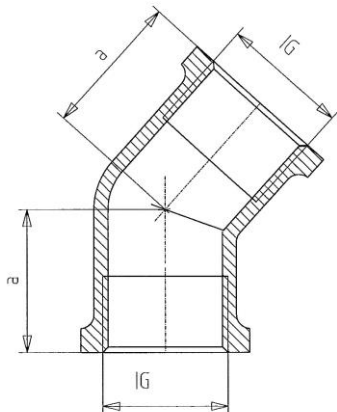

WST34MS45II

### Winkelstück, 45°, innen/innen

Artikel Nr.	Typen Nr.	Gewinde	a mm
194116	WST12MS45II	G 1/2 x G 1/2	23,5
194117	WST34MS45II	G 3/4 x G 3/4	24,0
194118	WST10MS45II	G 1 x G 1	30,5

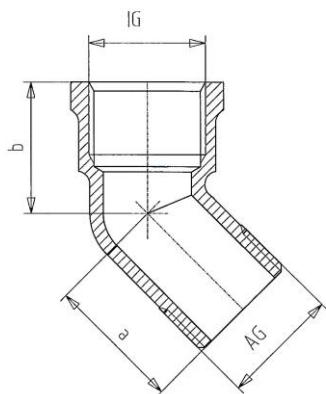

WST34MS45IA

### Winkelstück, 45°, innen/außen

Artikel Nr.	Typen Nr.	Gewinde	a mm	b mm
194119	WST12MS45IA	G 1/2 x G 1/2	28,0	23,0
194120	WST34MS45IA	G 3/4 x G 3/4	28,0	23,0
194121	WST10MS45IA	G 1 x G 1	34,5	30,5

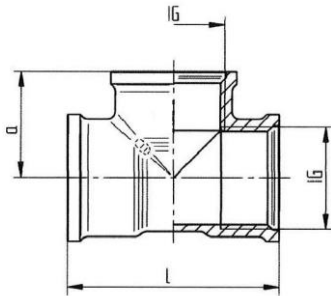

TST34MSIG

**T-Stück, 3 x Innengewinde**

Artikel Nr.	Typen Nr.	Gewinde	l mm	a mm
194122	TST14MSIG	G 1/4	40,0	20,0
194123	TST38MSIG	G 3/8	48,0	24,0
194124	TST12MSIG	G 1/2	53,0	27,0
194125	TST34MSIG	G 3/4	60,0	30,0
194126	TST10MSIG	G 1	66,5	33,0
194127	TST114MSIG	G 1 1/4	90,0	45,0
194128	TST112MSIG	G 1 1/2	93,0	46,5
194129	TST20MSIG	G 2	101,0	50,5

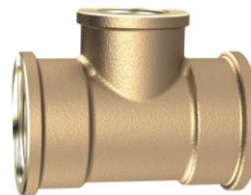
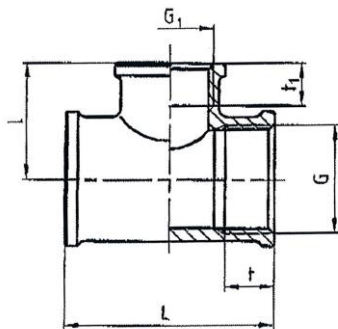

TRED101210MSIG

**T-Reduzierstück, 3 x Innengewinde**

Artikel Nr.	Typen Nr.	Gewinde G	Gewinde G <sub>1</sub>	t mm	t <sub>1</sub> mm	l mm	L mm
194130	TRED341234MSIG	G 3/4	G 1/2	12,0	10,5	28,5	51,0
194131	TRED101210MSIG	G 1	G 1/2	12,5	10,5	33,0	66,6
194132	TRED103410MSIG	G 1	G 3/4	12,5	12,0	33,0	66,6

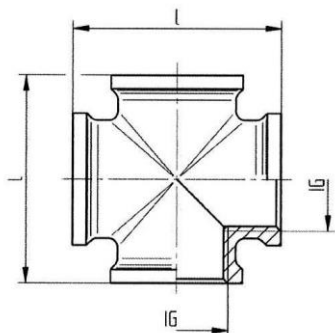

KST34MSIG

### Kreuzstück, 4 x Innengewinde

Artikel Nr.	Typen Nr.	Gewinde IG	l mm
194133	KST12MSIG	G 1/2	52,0
194134	KST34MSIG	G 3/4	61,0

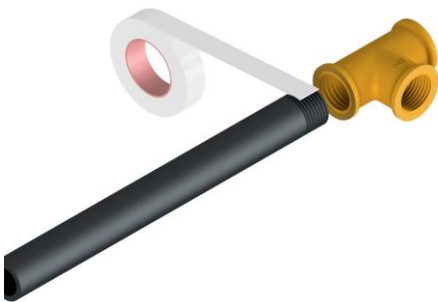

Um eine bestmögliche Dichtheit der Verbindung zu erzielen, empfehlen wir die Aufbringung eines geeigneten Dichtmittels z.B. unseren Gewindedichtfaden, Art.Nr. 114124 (Hanf nicht geeignet)



Damit mögliche Brüche durch übermäßiges Verschrauben vermieden werden können, prüfen Sie bitte die oben genannte Beschichtung auf Überschuss.



Verbinden Sie die Armatur mit der Leitung. Achten Sie darauf, dass die Leitung nicht in der Armatur überdreht wird. Überprüfen Sie hierzu bitte die Gewindelänge des Fittings und schrauben Sie das Rohr nicht über diese Länge hinaus. Vermeiden Sie mögliche Deformierungen der Armatur und der Leitung durch zu starken Anzug mittels Rohrzanze.